

PLAN VIEW

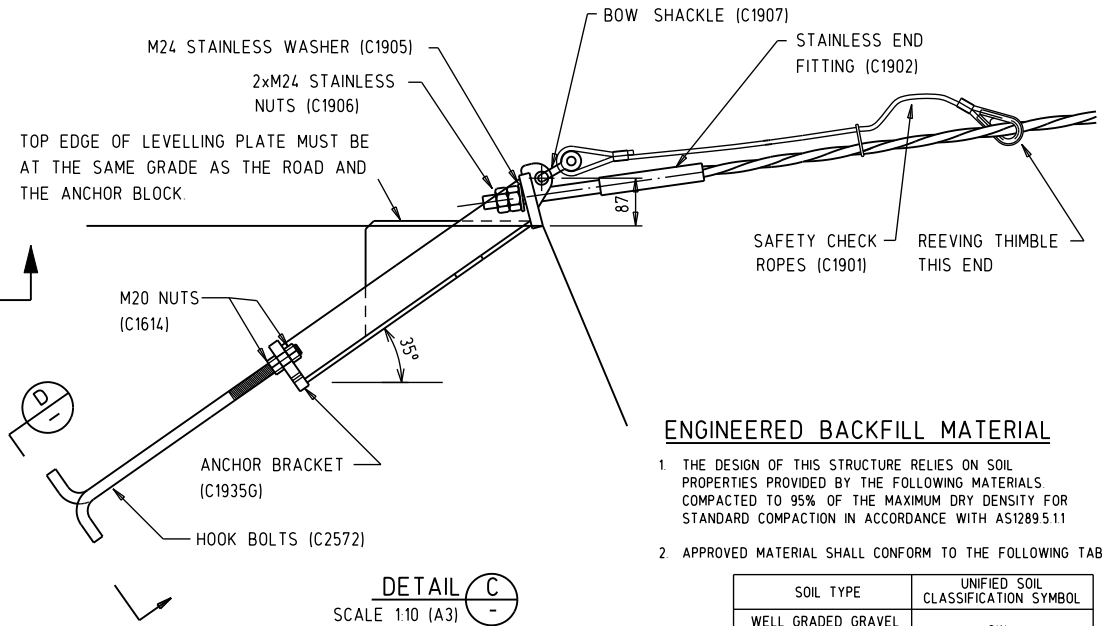

DETAIL C
SCALE 1:10 (A3)

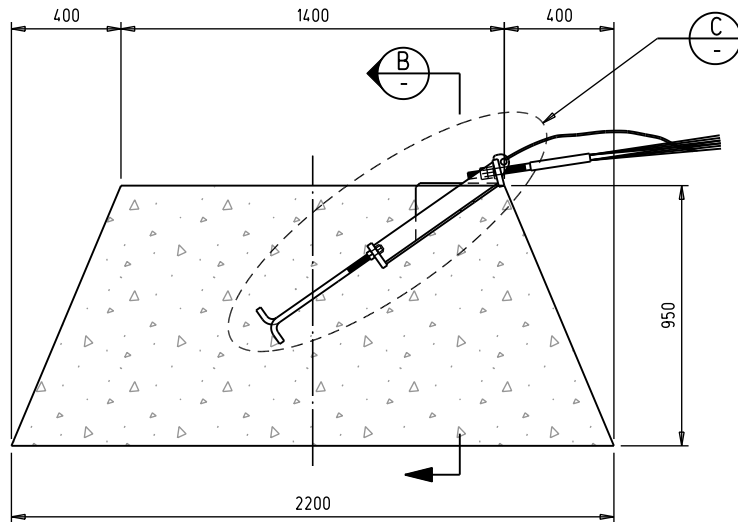

SECTION A

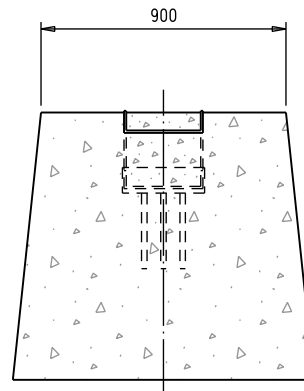

SECTION B

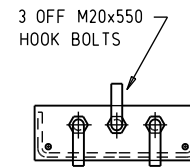

VIEW D

ENGINEERED BACKFILL MATERIAL

1. THE DESIGN OF THIS STRUCTURE RELIES ON SOIL PROPERTIES PROVIDED BY THE FOLLOWING MATERIALS COMPACTED TO 95% OF THE MAXIMUM DRY DENSITY FOR STANDARD COMPACTION IN ACCORDANCE WITH AS1289.5.11
2. APPROVED MATERIAL SHALL CONFORM TO THE FOLLOWING TABLE:

SOIL TYPE	UNIFIED SOIL CLASSIFICATION SYMBOL
WELL GRADED GRAVEL OR SANDY GRAVEL	GW
POORLY GRADED GRAVEL OR SANDY GRAVEL	GP
WELL GRADED SAND OR GRAVELLY SAND	SW
POORLY GRADED SAND OR GRAVELLY SAND	SP

3. INSITU SOIL SURROUNDING THE ANCHOR BLOCK AND BACKFILL MATERIAL ADJACENT TO THE ANCHOR BLOCK SHALL COMPLY WITH THESE UNIFIED SOIL CLASSIFICATIONS SELECT FILL AND INSITU MATERIAL SHALL HAVE A MAXIMUM LINEAR SHRINKAGE, DETERMINED IN ACCORDANCE WITH AS 1289.3.4.1, OF 8 PERCENT.

RECOMMENDED PARTICLE SIZE GRADING FOR BACKFILL MATERIAL:

SELECT FILL GRADING REQUIREMENTS	
SIEVE APERTURE	MASS OF SAMPLE PASSING* %
mm	
75.0	100
9.5	50-100
2.36	30-100
0.60	15-50
0.075	0-25
* DETERMINED IN ACCORDANCE WITH AS 1289.3.6.1	

CONCRETE

1. COMPRESSIVE STRENGTH OF CONCRETE AT 28 DAYS SHALL BE 32MPa.

CAD FILE - WRSTD28.DGN 24/4/07

ISSUE	Description	Chkd	Date
4	NOTES AMENDED	AJP	24/4/07
3	ANCHORS & LIFT LUGS REMOVED	AJP	7/6/06
2	NOTES AMENDED		
1	INITIAL ISSUE	GPP	22/8/03

INGAL Civil Products

127-141 Bath Road, Kirrawee, NSW, 2232 Australia
 Telephone 61-2-9710 5555, Facsimile 61-2-9542 3667, Internet www.ingalcivil.com.au
 © Industrial Galvanizers Corporation Pty Ltd ACN 000 545 415 (2003)
 This drawing is the subject of COPYRIGHT. No part of it may be used, reproduced or copied by any means or in any form without the prior permission of the owner.

PROJECT **INGAL FLEXFENCE WIRE ROPE SAFETY BARRIER**

TITLE **TYPE 2 CONCRETE ANCHOR BLOCK STANDARD END TERMINAL**

DATE 22/8/03	INGAL CIVIL PRODUCTS DRAWING No.
DRAWN A PURDON	WR-STD-28
DESIGNED BLUE SYSTEMS	
CHECKED T.C.	ISSUE No.
MATERIAL AS SHOWN	4
FINISH AS SHOWN	
SCALE 1:20 (A3) UNO.	