

Ingal Civil Products

A Division of Industrial Galvanizers Corporation Pty.Ltd.



# Product Manual

## T-39 Thriebeam

NCHRP 350 test level 3&4 compliant barrier



release 001

T-39 is licensed to Ingal Civil Products by Trinity Industries Inc. of the U.S.A.

## 1.0 INTRODUCTION

T-39 Thriebeam Barrier is the latest innovation in steel safety barrier systems providing superior design, rapid installation and driver confidence. T-39 has been fully crash tested and evaluated according to specifications for Test Level 3 (TL3) and Test Level 4 (TL4) of the US National Cooperative Highway Research Program Report 350 (NCHRP Report 350) and the anticipated update to NCHRP Report 350.

Traditional 'deemed to comply' C posts have been replaced with specially engineered Steel Yielding Line Posts (SYLP's) in order to prevent vehicle snagging, thus eliminating the requirement for blocking pieces. This, together with rail splices located mid-span between posts, results in reduced working widths, an easier to install system and a fully compliant NCHRP Report 350 safety barrier.

## 2.0 STANDARDS AND APPROVALS

T-39 has been fully crash tested to comply with the following standards;

- Australian Standard AS/NZS 3845:1999
- National Cooperative Highway Research Program (NCHRP) Report 350  
Test Level 3 (TL3) and Test Level 4 (TL4)

## 3.0 BARRIER SPECIFICATION

Dimensions:

T-39 Panel:	4000mm net laying length
SYLP:	1830mm long
Flange Protector:	150mm long w-beam section
Post Bolt:	5/8" x 1.75" slotted countersunk bolt
Splice Bolt:	M16 x 32mm mushroom head, grade 8.8

Barrier Height: 990mm above ground level

Post Height: 813mm above ground level

Post Spacing: 2000mm

System Width: 316mm (median barrier)  
233mm (verge barrier)

Finish: Galvanized to AS/NZS 4680:1999



820kg small car - 100km/h and 20°



8000kg single unit truck - 80km/h and 15° (TL4 impact)



2270kg pick-up truck - 100km/h and 25° (TL3 impact)

## 4.0 TECHNICAL DATA

### 4.1 Functional Principles

T-39 contains errant vehicles through the development of lateral forces, which gradually redirect the vehicle toward the roadway. During impact, lateral resistance is developed as the beam deflects laterally. As it deflects and stretches, large tensile forces develop in the beam and redirect the vehicle.

In addition to the tensile forces, the beam, which is supported at regular intervals by the SYLP's, also develops considerable bending resistance, which imparts additional redirective forces to the vehicle.

Structural failure of traditional steel safety barrier systems during impact is occasionally the result of splice connections when it is located near a post. The T-39 system has relocated the splice to the mid-span of the beam in order to reduce splice stresses and reduce the likelihood of rail rupture.

### 4.2 Barrier Deflection

The working width is defined as the maximum width measured from the barrier face that is required to prevent an impacting vehicle from colliding with an object behind a road safety barrier system. This includes the dynamic deflection and the extra width due to the roll of the impacting vehicle. T-39 deflections and working widths are detailed as follows;

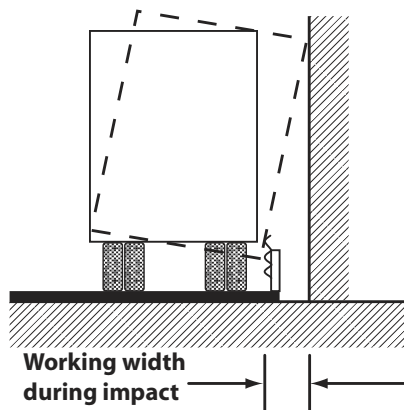

**Table 1: T-39 Deflections & Working Widths**

Vehicle Type	Impact Conditions	Barrier Configuration	Evaluation	Dynamic Deflection	Working Width
820kg Small Car	100km/h at 20°	Median Barrier	Crash Test	0.34m	0.88m
2270kg Pick-Up Truck (TL2)	70km/h at 25°	Verge Barrier	Calculation	0.35m	0.35m
2270kg Pick-Up Truck (TL3)	100km/h at 25°	Verge Barrier	Crash Test	0.63m	0.63m
8000kg Single Unit Truck (TL4)	80km/h at 15°	Verge Barrier	Crash Test	0.81m	1.86m

During the TL4 Impact (8000kg Single Unit Truck), the truck box exhibited an estimated roll angle of over 30° and extended more than 1m beyond the deflected rail. This area must be kept free of rigid vertical objects such as overhead/cantilever sign support and bridge piers when specified as a TL4 barrier. Refer to Figure 1.

When specified as a TL3 barrier, the working width is equivalent to the dynamic deflection of the system.



**Figure 1: Working Width for TL4 Impact**

### 5.0 APPLICATION BENEFITS

The T-39 Thriebeam Barrier offers the following application benefits when compared to existing 'deemed to comply' barrier systems with C posts;

- Fully compliant to NCHRP Report 350 Test Level 3 (TL3) and Test Level 4 (TL4)
- Reduced working widths and site earthworks since posts can be installed 350mm closer to the roadway (as compared to the current TL4 'deemed to comply' system).

- No blocking pieces required provides for a more easily installed and maintained system.
- Successfully crash tested as a verge (single sided) and median (double-sided) barrier.

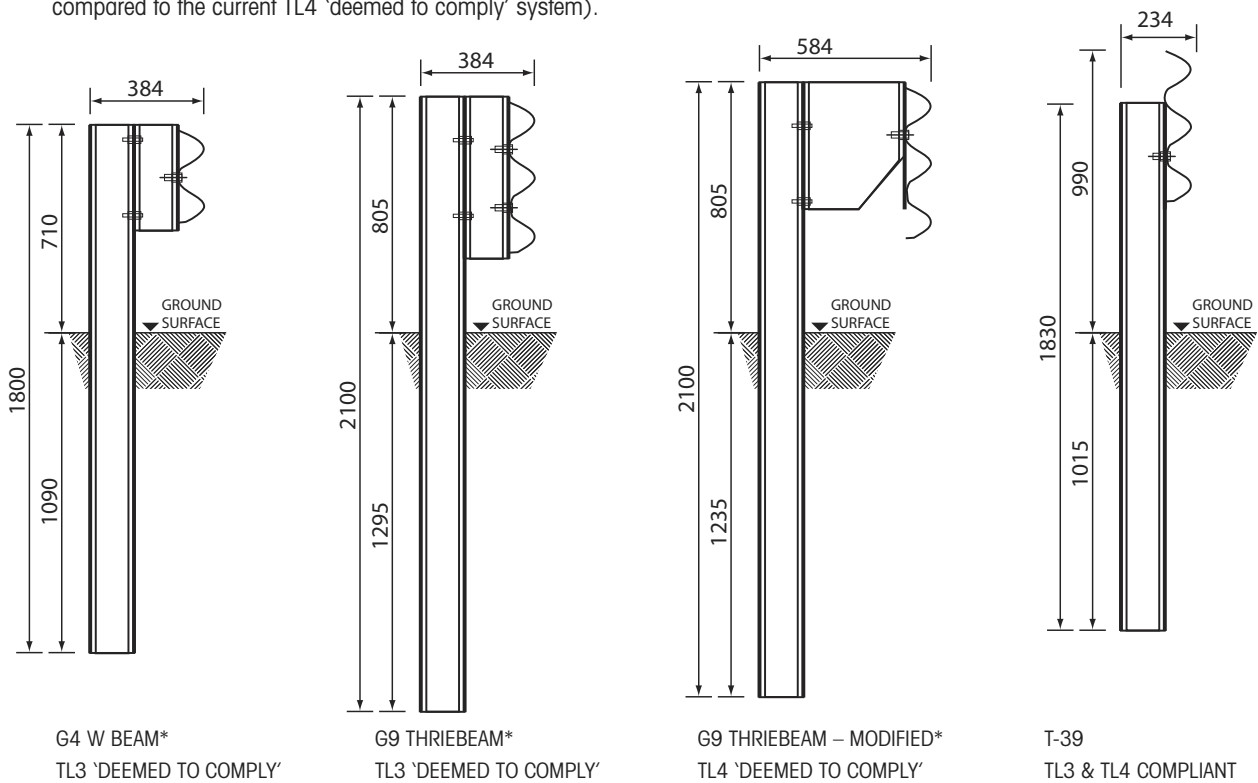

Figure 2: Barrier Comparisons – Verge Applications (\*Denotes with C posts)

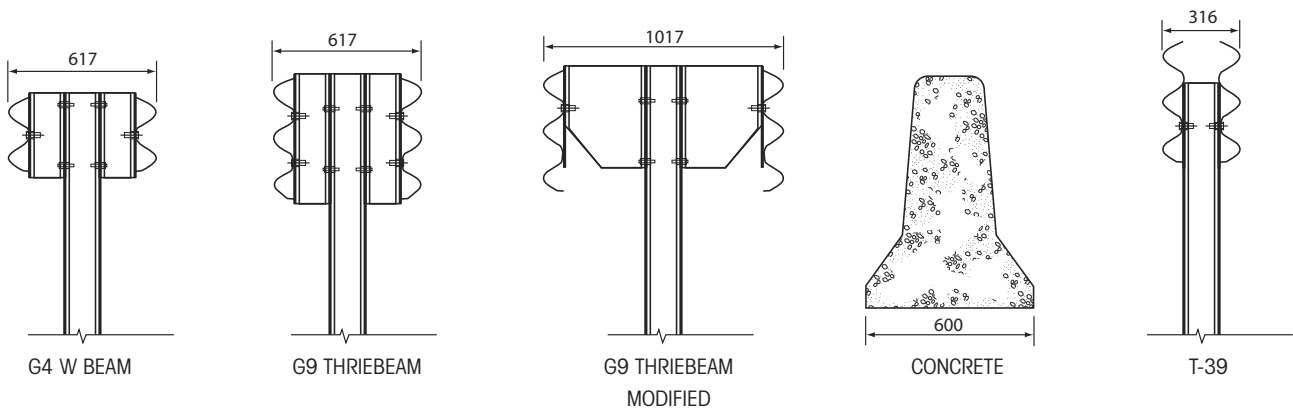

Figure 3: Barrier Comparisons – Median Applications

## 6.0 INSTALLATION

### 6.1 Site Preparation

T-39 should be located at least 600mm (measured from back of post) in front of embankments that require shielding. This distance is required to provide proper post support.

The approach terrain to the barrier must be level. Grading to 1:20 is preferable and 1:10 maximum slope should be present. Steeper slopes can result in the vehicle impacting the barrier at other than the design height.

The expected deflection of the barrier (Table 1) should not exceed the available room to deflect.

Ensure the area has been inspected for underground hazards and that suitable traffic control is in place.

### 6.2 Recommended PPE

The following Personal Protective Equipment (PPE) is recommended for the installation of T-39;

- Hard hat (if required by the site supervisor)
- Footwear offering a minimum of steel toe caps and adequate ankle support
- Hi visibility vests or clothing
- Ear protection
- Protective gloves
- Eye Protection
- Sun protection (wide brimmed hat, sleeved shirt, sunscreen)

### 6.3 Installation Sequence

The following written instructions should be read in conjunction with the enclosed Ingal Civil Products Drawings:

DEV-06-04-01	T-39 Verge Application General Arrangement
DEV-06-04-02	T-39 Verge Application Assembly
DEV-06-04-03	T-39 Median Application General Arrangement
DEV-06-04-04	T-39 Median Application Assembly
DEV-06-04-05	T-39 Transition to Type B Guardfence (Victoria)
DEV-06-04-06	T-39 Transition to G4 W Beam

#### 6.3.1 Installation of Posts

1. Post locations are marked ensuring the hazard to be protected is located outside the expected working width of the barrier.
2. Posts are installed at 2000mm centres. The tolerance on post spacing shall be plus or minus 25mm. The posts are driven directly into the ground and should be vertical. (The post installation process shall not cause damage to the post, such that it reduces the effective operation of the safety barrier or its design life, or introduces sharp tearing edges, nor shall it

cause damage to pavement). Alternately, a hole can be augured and the post placed in the hole. The posthole is then backfilled with the material that was excavated. Material should be placed in layers and suitably compacted. The posts should be installed to a depth of 1015mm. The four 21mm diameter holes in the posts should be located at ground level when installation is complete.

If rock is encountered, posts should be set near the roadside edge of a 530mm to 580mm hole drilled to a depth of 610mm and backfilled with a granular, compressible material so that the post can rotate back at the groundline upon impact. The size and depth of the drilled hole may vary depending upon the depth of soil above the rock. Please refer to Section 6.5 for details.

3. When a lateral force of 1kN is applied in any direction within the top 200mm of a post before the rail is secured, movement of the post at ground level shall not be more than 3mm

#### 6.3.2 Installation of Rails

1. The holes in the rails for attachment to the posts are slotted to allow for tolerances in post spacing. If the post and rails are out of alignment, holes may be drilled into the rail and the rail may be saw cut. Flame cutting is not permitted. Coating repairs are to be carried out using a zinc rich paint or metallic repair product.
2. Rails are attached to the posts using the 5/8" countersunk bolts.

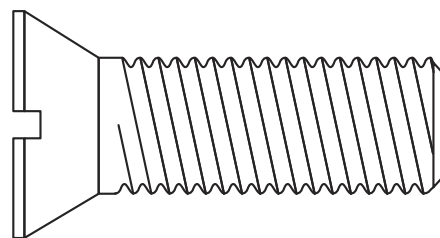

**Figure 4: Countersunk Post Bolt**

3. The rails are spliced mid-span between posts using M16x32mm mushroom head bolts. Washers are NOT used.
4. W-beam flange protectors are located between the rail and post connection. The flange protector nests in the bottom two corrugations of the beam as the beam bears against the post.
5. It is recommended that posts be installed only a few metres ahead of rail assembly to ensure correct post spacing and alignment. On curves, the rails can be laid on the ground to determine post locations.
6. The tolerance on the height of the barrier is plus or minus 20mm.

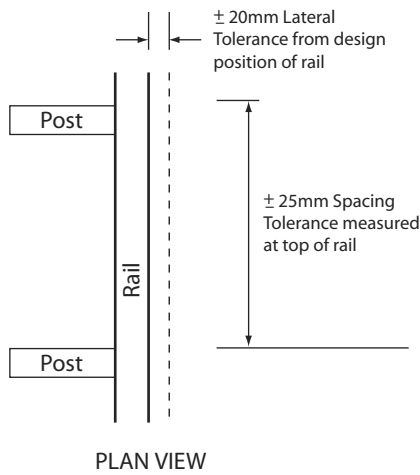

Figure 5: Post Tolerances Plan View

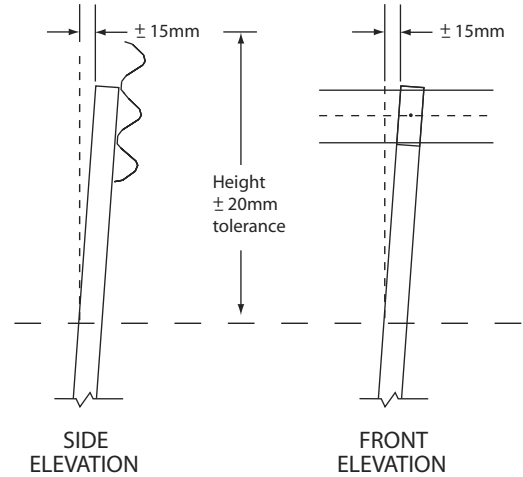

Figure 6: Post Tolerances - Side & Front View

**6.4 T-39 Installation Checklist**

To ensure the correct installation of T-39, you must have answered yes for each question.

Is the hazard to be shielded located outside the expected dynamic deflection of T-39	<input type="checkbox"/> Yes	<input type="checkbox"/> Yes
Have the posts been positioned at 2000mm spacings	<input type="checkbox"/> Yes	<input type="checkbox"/> Yes
Are the posts installed at the correct height of 815mm	<input type="checkbox"/> Yes	<input type="checkbox"/> Yes
Have the posts been installed within the allowable tolerances;	<input type="checkbox"/> Yes	<input type="checkbox"/> Yes
• Post spacing $\pm 25\text{mm}$		
• Post height $\pm 20\text{mm}$		
Has the rail been spliced observing the correct rail lap	<input type="checkbox"/> Yes	<input type="checkbox"/> Yes
Are the rail laps located mid-span between posts	<input type="checkbox"/> Yes	<input type="checkbox"/> Yes
Are the flange protectors installed behind the rail at each post location	<input type="checkbox"/> Yes	<input type="checkbox"/> Yes
Are the rails attached to the posts using the countersunk head bolt	<input type="checkbox"/> Yes	<input type="checkbox"/> Yes
Are the rails spliced with M16x32mm mushroom head bolts	<input type="checkbox"/> Yes	<input type="checkbox"/> Yes
Are all the bolts snug tight	<input type="checkbox"/> Yes	<input type="checkbox"/> Yes
Is the T-39 suitably transitioned and anchored with approved terminals	<input type="checkbox"/> Yes	<input type="checkbox"/> No

**6.5 Posts in Rock and in Mowing Strips**

A guardrail post is designed to absorb some crash energy through post rotation in the soil prior to post failure. Restraining guardrail posts by setting them in narrow holes drilled into solid rock, by setting them in concrete, or by placing a mowing strip around the posts can lead to early post failure, placing more load on the rail element itself and possibly leading to rail rupture and subsequent penetration by an impacting vehicle.

Posts in solid rock should be set near the roadside edge of a 560mm hole drilled 610mm deep and backfilled with a compressible material so that the post can rotate approximately 380mm at the ground line upon impact. For locations where solid rock is below the surface the size and depth of the drilled hole will vary as shown, depending on the depth of soil above the solid rock.

When mowing strips are required, a minimum 'leave-out' area in the strip that will allow a minimum 180mm of post deflection at the ground line is recommended. This area is then backfilled with a low strength (less than 0.85MPa) concrete mix.

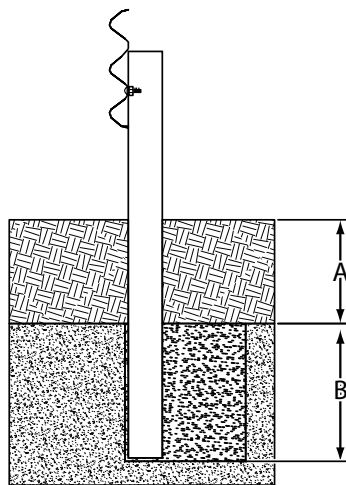

Either hole configuration acceptable

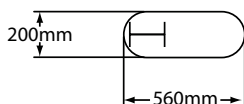
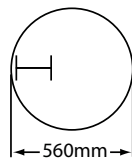

Note: For overlying soil depths (A) ranging from 0 to 460mm, the depth of the required drilling (B) is equal to 610mm

**Figure 7: Post in Solid Rock – Case 1**

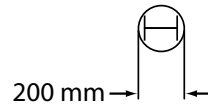
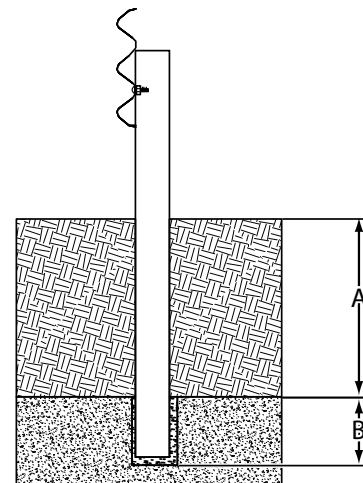

Note: For overlying soil depths (A) ranging from 460mm to the embedment depth of the post, depth of required drilling (B) is equal to either 305mm or the desired embedment depth minus the depth of the soil, whichever is less.

**Figure 8: Post in Solid Rock – Case 2**

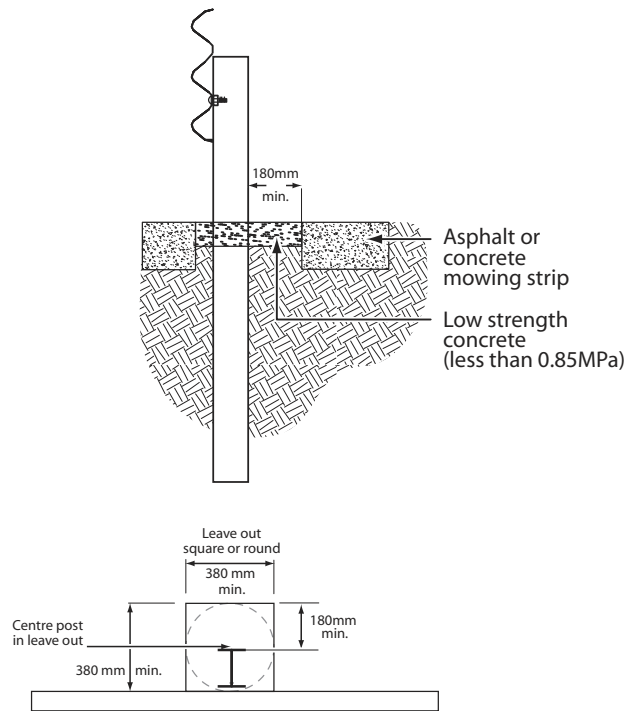

**Figure 9: Post in Mowing Strips**

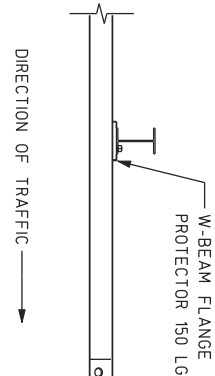

PLAN VIEW

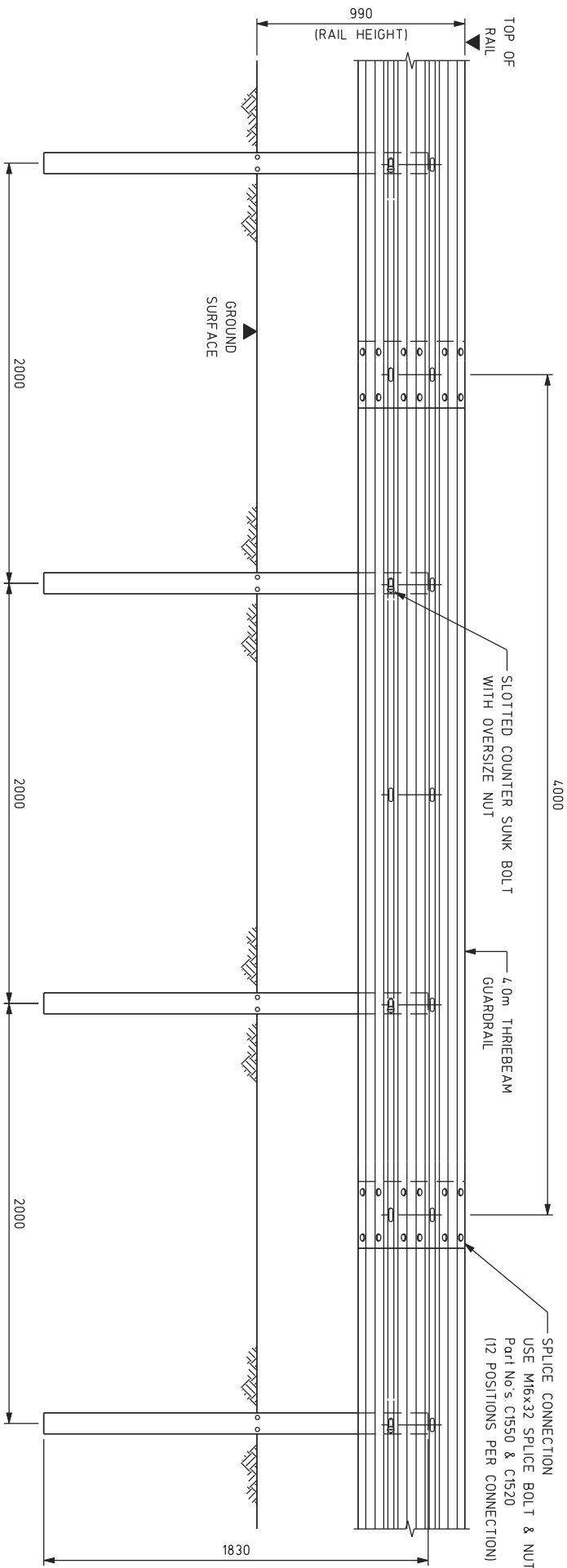

ELEVATION

The T-39 Thriebeam Barrier has been approved by the US Federal Highway Administration as conforming to NCHRP Report 350 Test Level 3 (TL3) and Test Level 4 (TL4). This report has been adopted as the basis of testing for AS/NZS 3845:1999 "Road Safety Barrier Systems".

ISSUE	INITIAL	ISSUE	Description	CHKD	Date
1				A.J.P.	29/9/06

**INGAL CIVIL PRODUCTS**

**INGAL Civil Products**

127-141 Bain Road, Kircowrie, NSW, 2232, Australia  
 Telephone: 61-3-9701 3553; Facsimile: 61-2-9542 3867; Email: [ingal@ingal.com.au](mailto:ingal@ingal.com.au)  
 Website: [www.ingal.com.au](http://www.ingal.com.au)  
 This drawing is the subject of Copyright. No part of it may be used, reproduced or copied by any means or in any form without the prior permission of the owner.

PROJECT: THRIEBEAM BARRIER SYSTEM  
 TITLE: GENERAL VERGE APPLICATION  
 TITLE: GENERAL ARRANGEMENT

DATE: 29/9/06	INGAL CIVIL PRODUCTS
DRAWN: A.PURDON	DRAWING NO.: DEV-06-04-01
DESIGNED: TRINITY IND	ISSUE NO.: 1
CHECKED: T.C.	
MATERIAL AS SHOWN	
FINISH AS SPECIFIED	
SCALE: 1:20 AT A3	

The T-39 Thriebeam Barrier has been approved by the US Federal Highway Administration as conforming to NCHRP Report 350 Test level 3 (TL3) and Test level 4 (TL4). This report has been adopted as the basis of testing for AS/NZS 3845:1999 "Road Safety Barrier Systems".

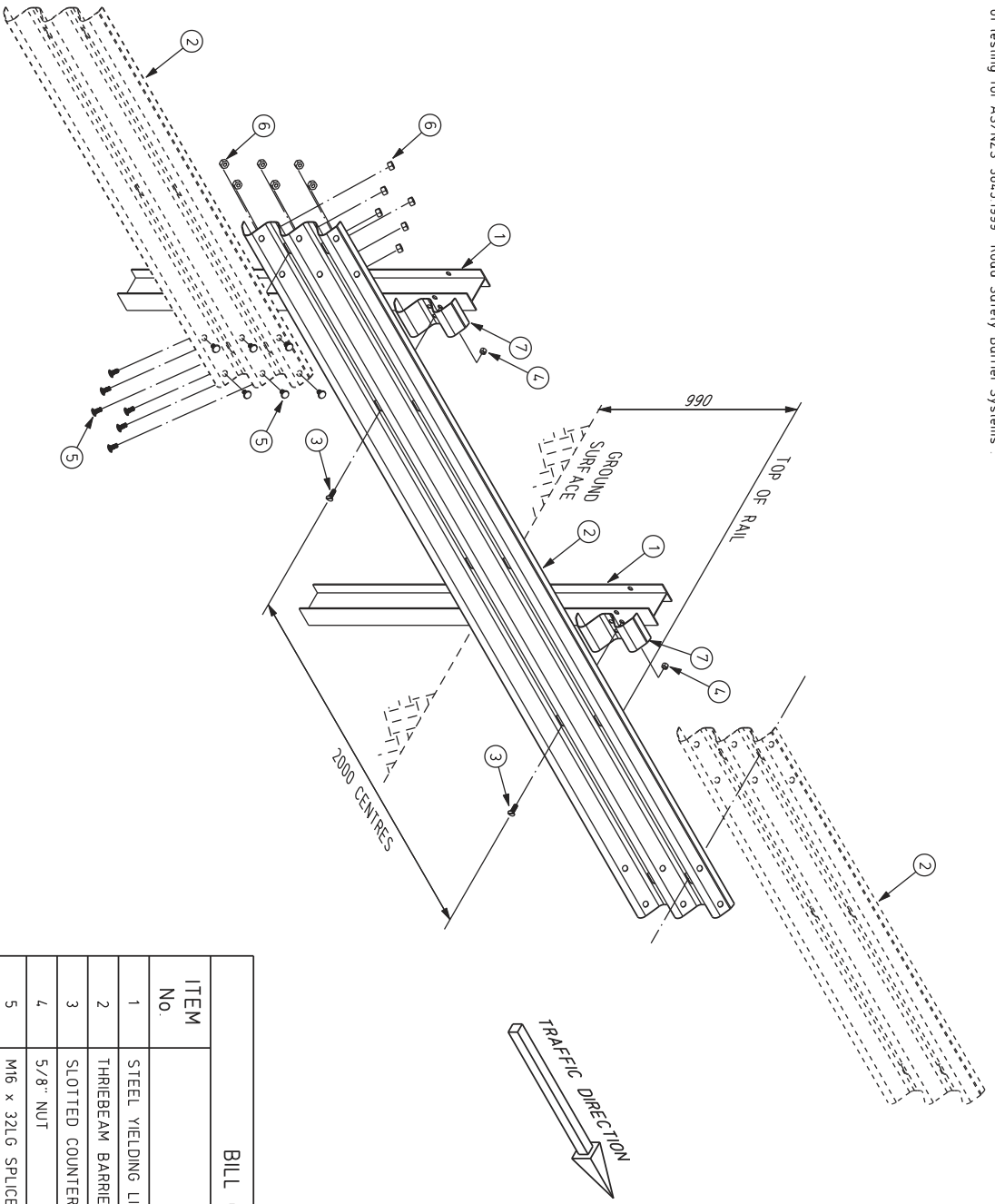

**BILL OF MATERIALS**

ITEM No.	DESCRIPTION	QTY
1	STEEL YIELDING LINE POST - 1830 LONG	2
2	THRIEBEAM BARRIER, 4.0m N.L.L. & 1000mm SLOT SPACINGS	1
3	SLOTTED COUNTER SUNK BOLT 5/8" x 1 3/4" LONG	2
4	5/8" NUT	2
5	M16 x 32LG SPLICE BOLT - MUSHROOM HEAD	12
6	M16 OVERSIZE NUT	12
7	FLANGE PROTECTOR	2

**INGAL Civil Products**

127-141 Bohn Road, Kiriwina, NSW, 2232, Australia  
 Telephone: 61-2-970 5555, Facsimile: 61-2-9542 3867, Internet: www.ingalcivil.com.au  
 © Ingal Civil Products Corporation Pty Ltd. ACN 000 545 415 120031  
 This drawing is the subject of Copyright. No part of it may be used, reproduced or copied by any means or in any form without the prior permission of the owner.

ISSUE	Description	Chgd	Date
1	INITIAL ISSUE	A.J.P.	29/9/06

PROJECT: **THRIEBEAM BARRIER SYSTEM**  
**T-39 VERGE APPLICATION ASSEMBLY**

TITLE: **GENERAL ARRANGEMENT**

DATE: 29/9/06	INGAL CIVIL PRODUCTS
DRAWN: A. PIRBON	DRAWING NO. DEV-06-04-02
CHECKED: T.C.	ISSUE NO. 1
MATERIAL: AS SHOWN	
FINISH: AS SPECIFIED	
SCALE: NIS	

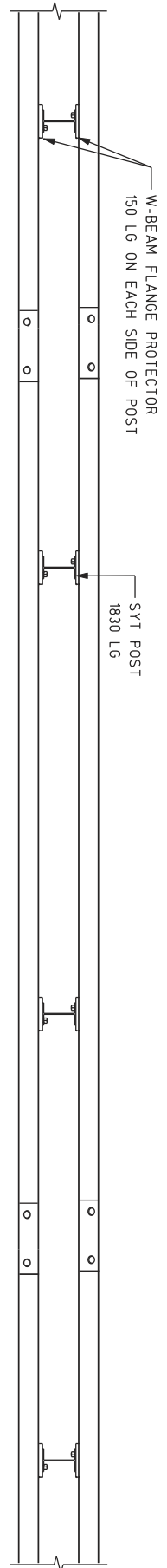

PLAN VIEW

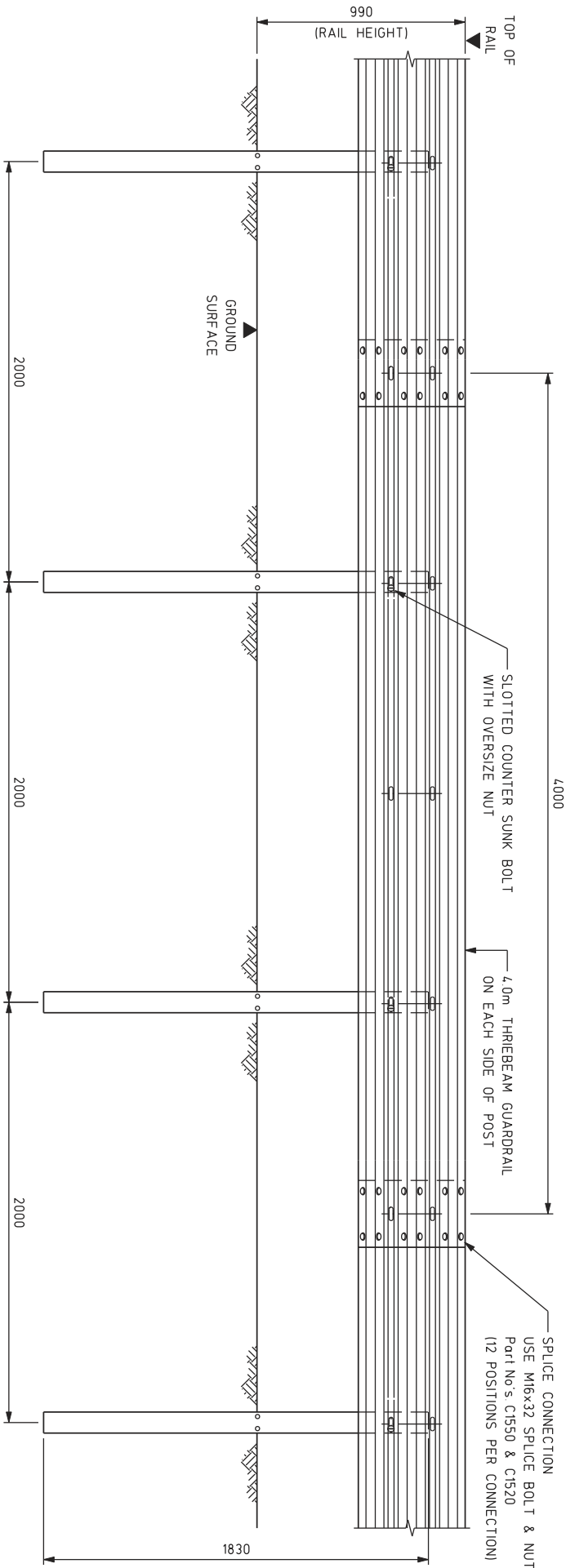

ELEVATION

The T-39 Thriebeam Barrier has been approved by the US Federal Highway Administration as conforming to NCHRP Report 350 Test level 3 (TL3) and Test level 4 (TL4). This report has been adopted as the basis of testing for AS/NZS 3845:1999 "Road Safety Barrier Systems".

ISSUE	INITIAL ISSUE	Description	Chkd	Date
1			AJP	29/9/06

**INGAL CIVIL PRODUCTS**

127-141 Bath Road, Kiriwong, NSW, 2232, Australia  
Telephone 61-2-970 5555; Facsimile 61-2-9512 3807; Internet www.ingal.com.au  
This drawing is the subject of Copyright. No part of it may be used, reproduced or copied by any means or in any form without the prior permission of the owner.

PROJECT **THRIEBEAM BARRIER SYSTEM**

TITLE **GENERAL ARRANGEMENT**

T-39 MEDIAN APPLICATION

DATE	29/9/06	INGAL CIVIL PRODUCTS DRAWING NO. <b>DEV-06-04-03</b>
DRAWN	A PURDON	
DESIGNED	TRINITY IND	
CHECKED	IC	
MATERIAL	AS SHOWN	ISSUE No. <b>1</b>
FINISH	AS SPECIFIED	
SCALE	1:20 AT A3	

The T-39 Thribeam Barrier has been approved by the US Federal Highway Administration as conforming to NCHRP Report 350 Test Level 3 (TL3) and Test Level 4 (TL4). This report has been adopted as the basis of testing for AS/NZS 3845:1999 "Road Safety Barrier Systems".

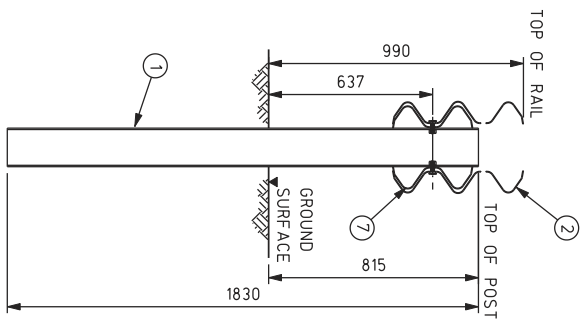
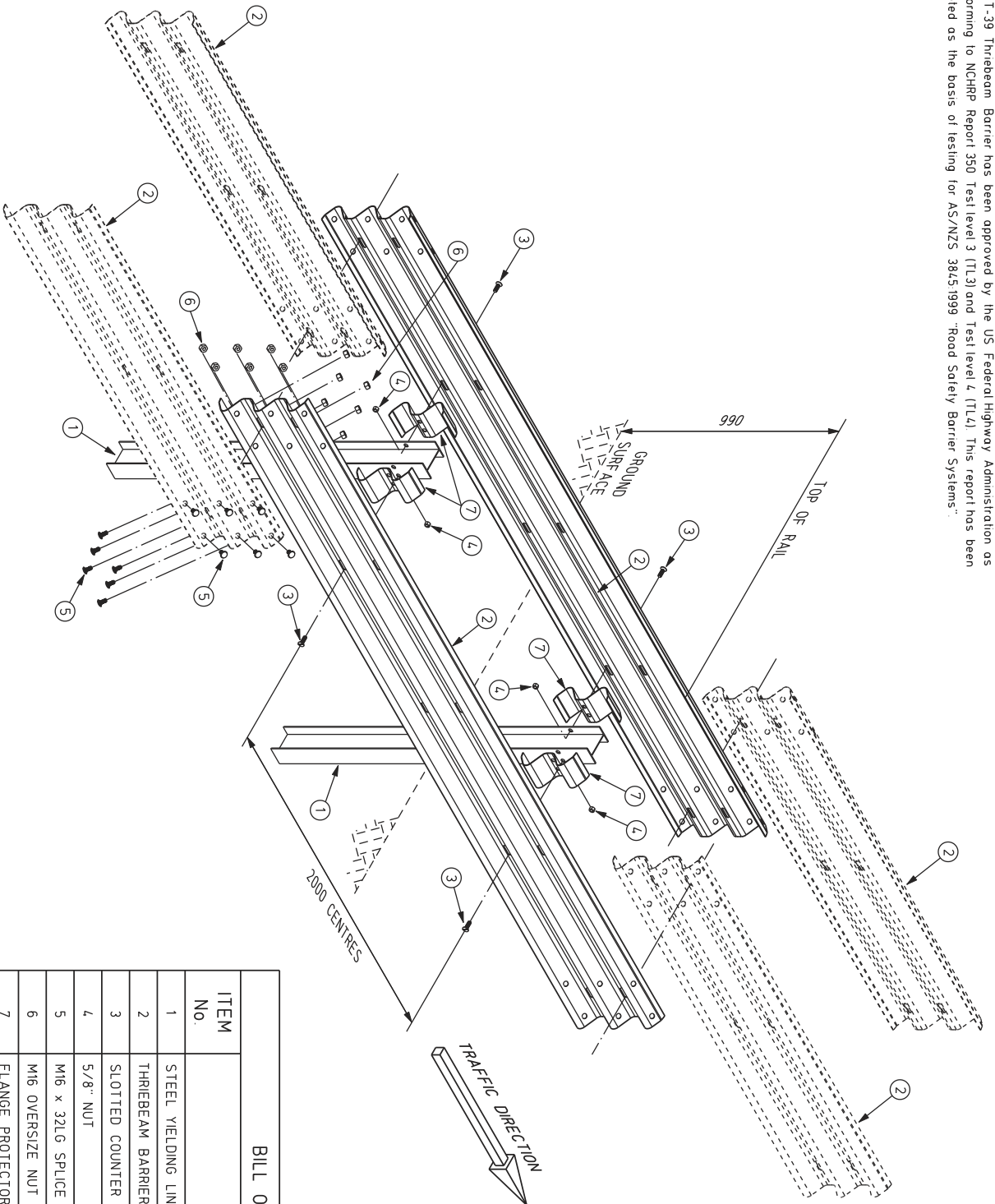

**BILL OF MATERIALS**

ITEM No.	DESCRIPTION	QTY
1	STEEL YIELDING LINE POST - 1830 LONG	2
2	THRIEBEAM BARRIER, 4.0m NLL & 1000mm SLOT SPACINGS	2
3	SLOTTED COUNTER SUNK BOLT 5/8" x 1 3/4" LONG	4
4	5/8" NUT	4
5	M16 x 32LG SPLICE BOLT - MUSHROOM HEAD	24
6	M16 OVERSIZE NUT	24
7	FLANGE PROTECTOR	4

ISSUE	Description	Chd	Date
1	INITIAL ISSUE	A.J.P.	29/9/06



**INGAL Civil Products**  
 127-143 Bona Road, Koroit, NSW, 2232, Australia  
 Telephone 61-2-971-9711  
 © Industrial Governors Corporation Pty Ltd - ACN 000 545 415 (2003)  
 This drawing is the subject of COPYRIGHT. No part of it may be used, reproduced or copied by any means or in any form without the prior permission of the owner.

PROJECT **THRIEBEAM BARRIER SYSTEM**  
 TITLE **T-39 MEDIAN APPLICATION ASSEMBLY**  
**GENERAL ARRANGEMENT**

DATE	29/9/06	INGAL CIVIL PRODUCTS
DRAWN	A PURDON	DRAWING NO.
DESIGNED	TRINITY MD	<b>DEV-06-04-04</b>
CHECKED	TC	ISSUE NO.
MATERIAL	AS SHOWN	<b>1</b>
FINISH	AS SPECIFIED	
SCALE	M15	

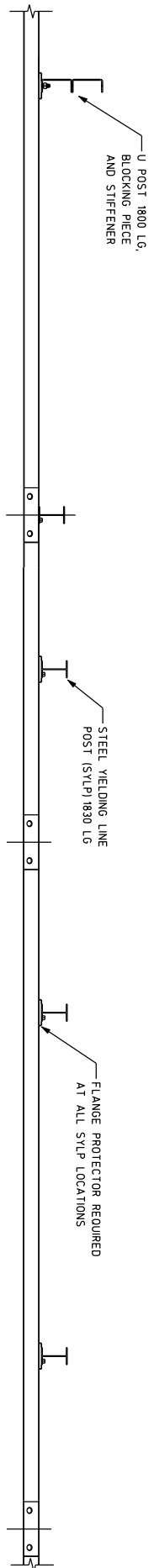

PLAN

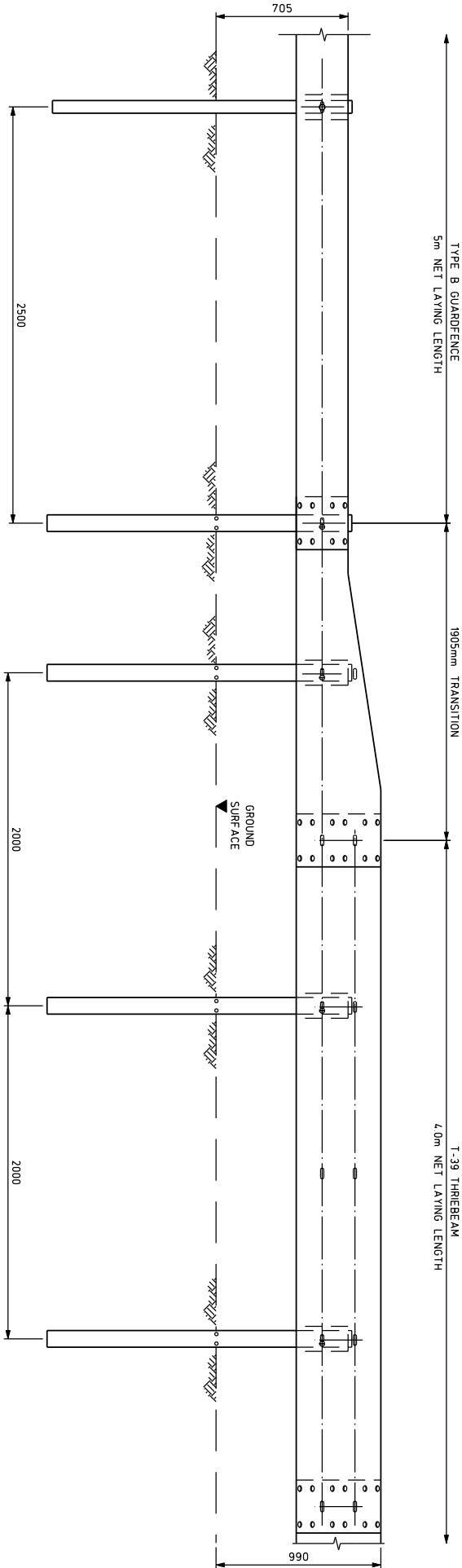

ELEVATION

ISSUE	NO.	DESCRIPTION	DATE
2	TYPE B FENCE HEIGHT MODIFIED	A.J.P. 02/07/07	
1	INITIAL ISSUE	A.J.P. 29/9/06	

**INGAL CIVIL PRODUCTS**

127-1/1 Bath Road, Kiriwapa NSW, 2322 Australia  
 Telephone 61-2-9710 5555, Facsimile 61-2-9542 3667, Internet www.ingalcivil.com.au  
 This drawing is the property of Ingal Civil Products Pty Ltd. It is to be used only for the project and site specified. It is not to be copied, reproduced or used in any form without the prior permission of the owner.

**PROJECT THREEBEAM BARRIER SYSTEM**  
**T-39 TRANSITION TO TYPE B GUARDFENCE**

**TITLE GENERAL ARRANGEMENT**

DATE	29/9/06	INGAL CIVIL PRODUCTS
DRAWN	A. PURDON	DRAWING NO.
DESIGNED	T.M. AND	DEV-06-04-05
CHECKED	T.C.	ISSUE NO.
MATERIAL	AS SHOWN	2
FINISH	AS SPECIFIED	
SCALE	1:25 AT A3	

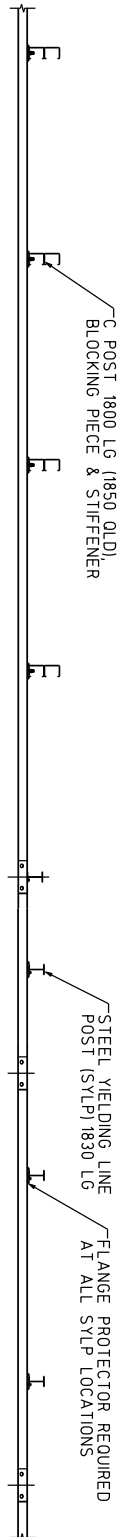

**PLAN**

DIRECTION OF TRAFFIC →

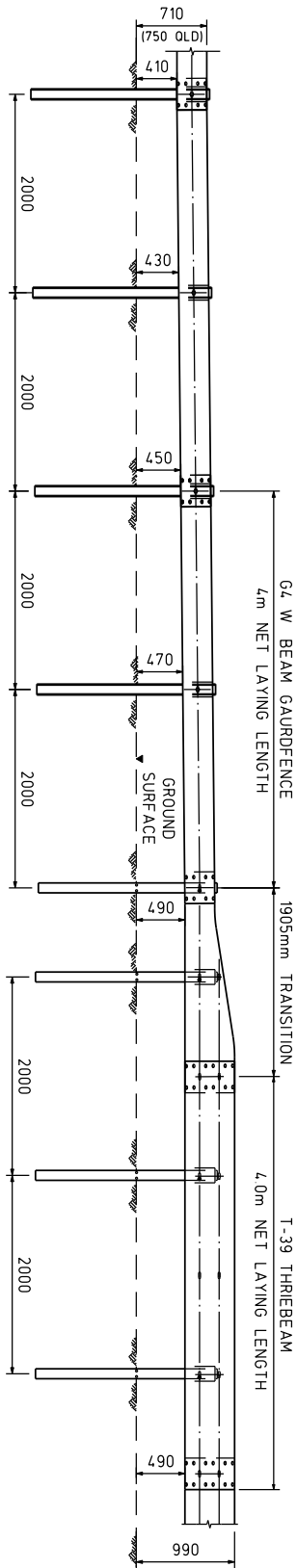

**ELEVATION**

ISSUE	Description	Chkd	Date
2	TRANSITION LENGTH MODIFIED	A.J.P.	09/10/07
1	INITIAL ISSUE	A.J.P.	29/9/06



**INGAL Civil Products**  
 171, 171 Bish Road, Kiriwapa, NSW, 2232, Australia  
 Telephone: 61-2-970 5555, Facsimile: 61-2-9542 3667, Internet: www.ingalcivil.com.au  
 © Ingal Civil Products Pty Ltd. ACN 000 545 415 (2003)  
 This drawing is the subject of COPYRIGHT. No part of it may be used, reproduced or copied by any means or in any form without the prior permission of the owner.

PROJECT **THRIEBEAM BARRIER SYSTEM**  
**T-39 TRANSITION TO G4 W BEAM**  
 TITLE **GENERAL ARRANGEMENT**

DATE	29/9/06
DRAWN	A. PARSON
DESIGNED	TRINITY IND
CHECKED	T.C.
MATERIAL	AS SHOWN
FINISH	AS SPECIFIED
SCALE	150 AT A3

INGAL CIVIL PRODUCTS  
 DRAWING NO. **DEV-06-04-06**  
 ISSUE NO. **2**



## Ingals Civil Products

A Division of Industrial Galvanizers Corporation Pty.Ltd.

**for more information**

### NEW SOUTH WALES

Sydney (Head Office)  
57-65 Airs Road,  
Minto, NSW 2566  
Ph: +61 2 9827 3333  
Fax: +61 2 9827 3300

### QUEENSLAND

Brisbane  
90 Mica Street  
Carole Park QLD 4300  
Ph: (07) 3271 3369  
Fax: (07) 3271 3299

### VICTORIA

Melbourne  
28-38 Albert Street  
Preston VIC 3072  
Ph: (03) 8470 0082  
Fax: (03) 9480 1834

### WESTERN AUSTRALIA

Perth  
9 Millrose Drive  
Malaga WA 6090  
Ph: (08) 9249 3155  
Fax: (08) 9249 3166

**[www.ingalcivil.com.au](http://www.ingalcivil.com.au)**  
or contact us on the web

